

# E3000S PrecisionHone

Precision controlled  
production honing with  
wide capability for low  
to high volumes



# Introduction to PrecisionHone

A high precision vertical honing machine with wide ranging capability to hone parts from small scale to heavy components, with a diameter range of 1.14mm to 80mm\* and a tolerance accuracy to 0.001mm, with sub-micron adjustment. With a compact footprint and Siemens control system, the PrecisionHone delivers precision control, operational efficiency and excellent return on investment.

## Precision Control

### Reliable accuracy and consistency

- Tolerance accuracy 0.001mm
- Sub-micron adjustment

## Operational Efficiency

### Reduced cost per part

- Optimised process
- Reduced cycle time
- Quick-change tooling
- Hands-free operation
- Operation by non-skilled workers
- Eliminates lapping operations
- Online diagnostics (Ethernet)
- Reduced maintenance
- Extended tool life

## Versatile and Flexible

### Wide ranging application and capability

- Low to high volume
- Automation capability
- Short stroke function
- Single pass cycle
- Heavy component capability
- Customised tooling
- Tailor-made abrasives



\*subject to application

# High quality, high performance, best value



“The value offered by PrecisionHone is best measured by the precise tolerances achieved, its versatility in application, the extended tool life it supports and the reduction in cost per part when competitively evaluated.”

Martin Elliott, Managing Director

## Workforce safety

- Failsafe interlocking guard system
- Closed door, push button operation

## Innovative in design, flexible in operation

- Unique spindle system with integral stone expansion
- Stable, accurate and repeatable stone adjustment
- Standard and short stroking
- One or two stage honing cycle
- Single pass cycle
- Sparkout timer
- Fully adjustable spindle speed
- Incremental feed adjustment from 0.1 – 30 micron/second
- Feed movement via precision ballscrew
- Adjustable stroking speed from 0.1 – 25m/min

## Electronic control system with Siemens' digital HMI

- Touch screen, conversational programming
- Tolerance accuracy to 0.001mm with sub-micron adjustment
- Download programmes to memory storage via USB port
- Remote access for assistance, immediate diagnosis, rapid support



## Operational Efficiency

- Quick change tooling
- Reduced cycle time
- Reduced work in progress

## Compact footprint, space-efficient

- W: 1400mm x D: 1670mm x H: 2600mm
- Base: single piece fabrication

# E3000S PrecisionHone in action

Operationally, PrecisionHone supports an optimised process; with tolerances and geometries to below  $2\mu$ , lapping stages can be eliminated altogether. With quick change tooling, the machine offers reduced cycle time, which in turn reduces work in progress and the associated costs. The control system supports conversational programming via an intuitive touch screen and with push-button, closed door, hands-free operation, this allows the machine to be run by both skilled and non-skilled operatives.

## PrecisionHone for

- Parts from small scale to heavy components
- Honing capacity from 1.14mm to 80mm\* diameter
- Low to high volume



## Ideal for

- Turbo Housings
- Flexure Sleeves
- Hydraulic Vane Bodies (large or heavy)
- Con Rods
- Water Pumps
- Valve Spools
- Fuel Injection Nozzles
- Small Cylinder Liners

Customised tooling and tailor-made abrasives are offered by Delapena to further extend the flexibility of this machine.

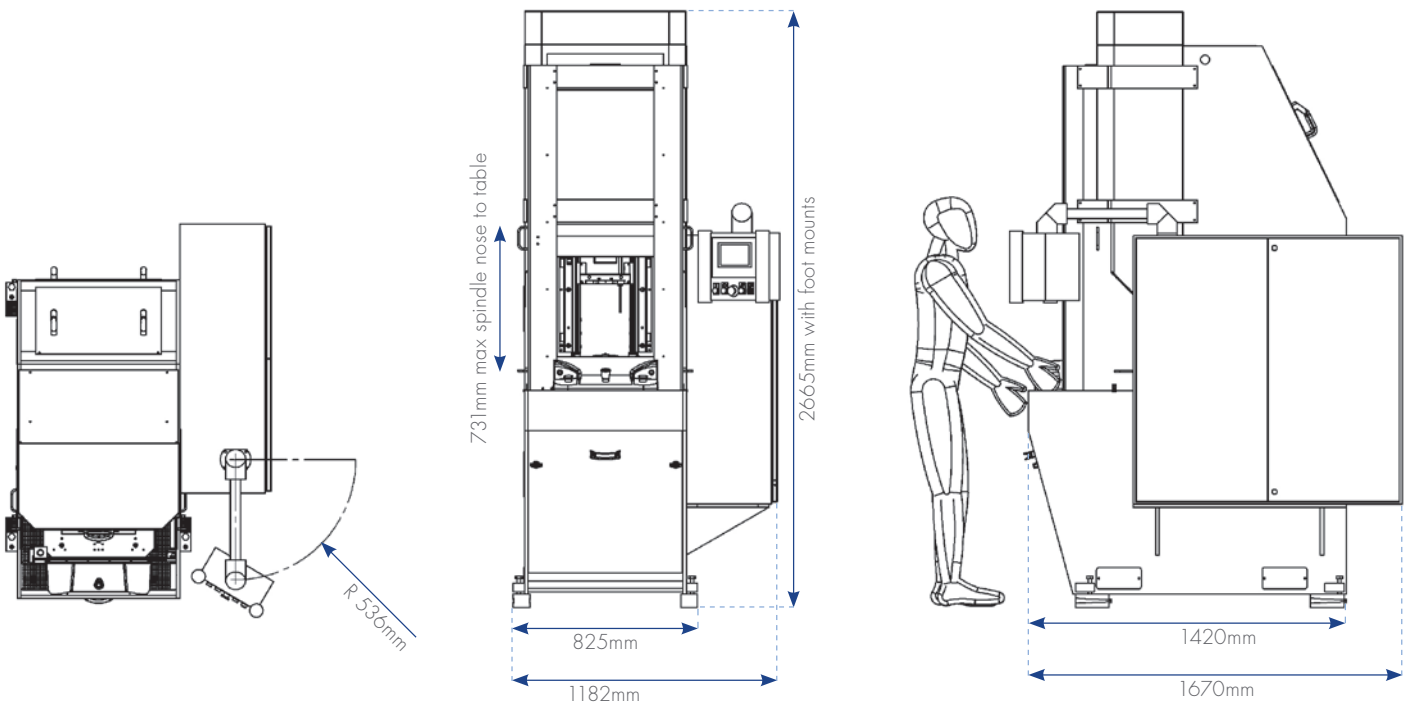

\*subject to application

## Capacity and Stroke

Diameter range	1.14mm – 80mm*
Maximum stroke length	Fully adjustable 2mm - 350mm
Stroking motor speed	Fully adjustable 0.1 – 25m/min
Stroking motor power	2.3 kw
Stroking movement	Precision recirculation ball screw
Short stroking	Fully adjustable length and frequency

## Spindle Drive and Stone Expansion

Spindle speed	Fully adjustable 250 - 3000 RPM
Spindle motor power	1.5 kW
Braking	Dynamic braking resistor
Feed type	Programmable
Feed rate	Fully adjustable 0.1 – 30 micron/second Two programmable speeds for each cycle and timer
Incremental feed	0.1 - 10 micron increments
Feed movement	Precision ball screw
Stone pressure	Variable maximum
Wedge retraction	Programmable
Wedge retraction speed	Programmable

## Electrical Equipment

Conformity	CE approved. Conforms to Machine Directive 2006/42/EC
Motor protection category	IP54
Standard electrical supply	380 – 415V, 3 Phase, 50Hz
Control voltage	24VDC

## Controller

Type	Siemens Digital Honing Control System
------	---------------------------------------

## Honing Fluid Filtration

System	Integral filter system combined
--------	---------------------------------

## Colour

Standard	White RAL 9002
----------	----------------

## Weight

Net	1750kg
Gross	1900kg

## Machine

Dimensions	1400mm (W) x 1670mm (D) x 2600mm (H)
------------	--------------------------------------

All dimensions are nominal. As a result of our policy of ongoing product development, Delapena reserves the right to revise specifications and design, without prior notice.

\*subject to application

## To optimise performance of the PrecisionHone

### Tooling & abrasives

Delapena offers a complete range of horizontal, vertical and heavy duty tooling, plus special tooling which is designed and manufactured to order. Our tooling is supported by a full range of Standard and Super Abrasives to satisfy the most demanding requirements for the honing process, providing size, geometry and surface finish.

We also provide a professional refurbishment service for all variants of honing heads, to support your preventative maintenance programme.

### Oils

We offer a range of high quality oils that focus upon:

- Improved surface finish
- Reduced environmental impact
- Improved operator health and safety, with low misting additives
- Improved lubricity, for reduced tool wear, better surface finishes and consistency for components
- Improved oil longevity for better value

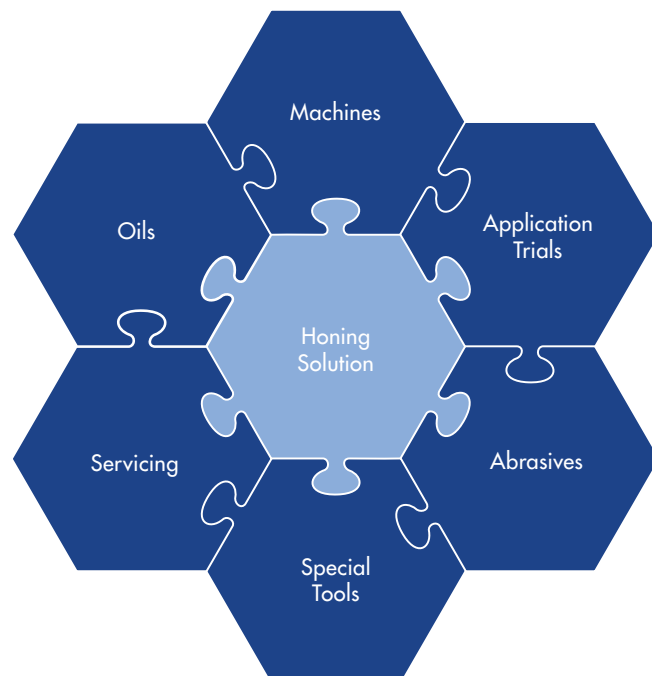

## To support use of the PrecisionHone

### Application trials

Each application trial includes data on surface finish, cycle times, abrasives and the best honing solution for the job.

### Commissioning

Every machine is commissioned by a Delapena engineer who manages the set up and provides training for all operatives.

### Training & continued education

To support clients to meet their Health & Safety requirements, we offer training as required for machine operatives. This is tailored to the specific client's requirements.

### Maintenance

The name Delapena is synonymous with reliability and the PrecisionHone is designed to be virtually maintenance free, with only annual checks required to ensure optimised operation. For reduced cost and downtime, the PrecisionHone can be remotely accessed via an internet connection to the Siemens control unit. This enables global remote access for assistance, immediate diagnostic assessment and rapid support.

## The wider range



### E1000S ProductionHone Mini

Competitively priced NC controlled horizontal honing machine for the production of small to medium sized batches.



### E2000S ProductionHone Maxi

The next step up from the ProductionHone Mini, offering increased capacity and torque, the ProductionHone Maxi is used for small long bores. A NC controlled horizontal honing machine with a wide range of rotational and reciprocation speeds, allowing the workpiece to automatically stroke over the tool.



### E2000S-XL CalibreHone

An innovative long bore precision honing machine, designed specifically to hone straight and tapered bores at lengths up to 800mm. The CalibreHone (E2000S-XL) achieves tolerances and geometries to below  $2\mu$ , for diameters up to 50mm.



### PowerHone

A competitively priced vertical honing machine for large and heavy components in small to medium sized batches and one-offs. Suitable for both through and blind bores, producing an excellent surface finish and repeatability. Designed and engineered for durability, efficiency and economical honing.



### EAS SpeedHone

SpeedHone is a compact, electronically controlled machine that de-skills the honing process. Tooling changes are quick and easy, making SpeedHone ideal for one off and batch production work. With enormous flexibility, SpeedHone is an essential machine for every tool room.

# Honing excellence

Part of Delapena Group, Delapena Honing Equipment is an innovator in the design and manufacture of high precision, technically advanced honing machines. Our company has an impressive history that spans over 85 years and we are exceptionally proud of our heritage. The name Delapena is synonymous with quality and is often used as a verb in the engineering world as the definitive for honing.

Today Delapena is recognised as a master in the honing market, operating internationally to offer complete honing solutions that include not only a range of technically advanced machines, but also the tooling, fixtures, abrasives and other consumables that optimise their performance. From manually operated machines to fully automated systems with Siemens electronic controls, Delapena offers a solution for every honing need and our customers rely upon our trusted expertise to optimise their process and surpass their objectives.



To learn more about the PrecisionHone or any other products and services from Delapena Honing Equipment please visit [www.delapena.co.uk](http://www.delapena.co.uk)

For further details or a quotation call **+44 (0) 1242 516341** or email [sales@delapena.co.uk](mailto:sales@delapena.co.uk)

## Delapena Honing Equipment Ltd

The Runnings | Cheltenham | Gloucestershire | GL51 9NJ | UK  
Tel: +44 (0)1242 516341 | Fax: +44 (0)1242 221246  
[sales@delapena.co.uk](mailto:sales@delapena.co.uk) | [www.delapena.co.uk](http://www.delapena.co.uk)



Delapena is a independently owned British company

