

HD Super Tooling

For Honing of long, larger diameter tubes $\varnothing 108$ to 1,222 mm

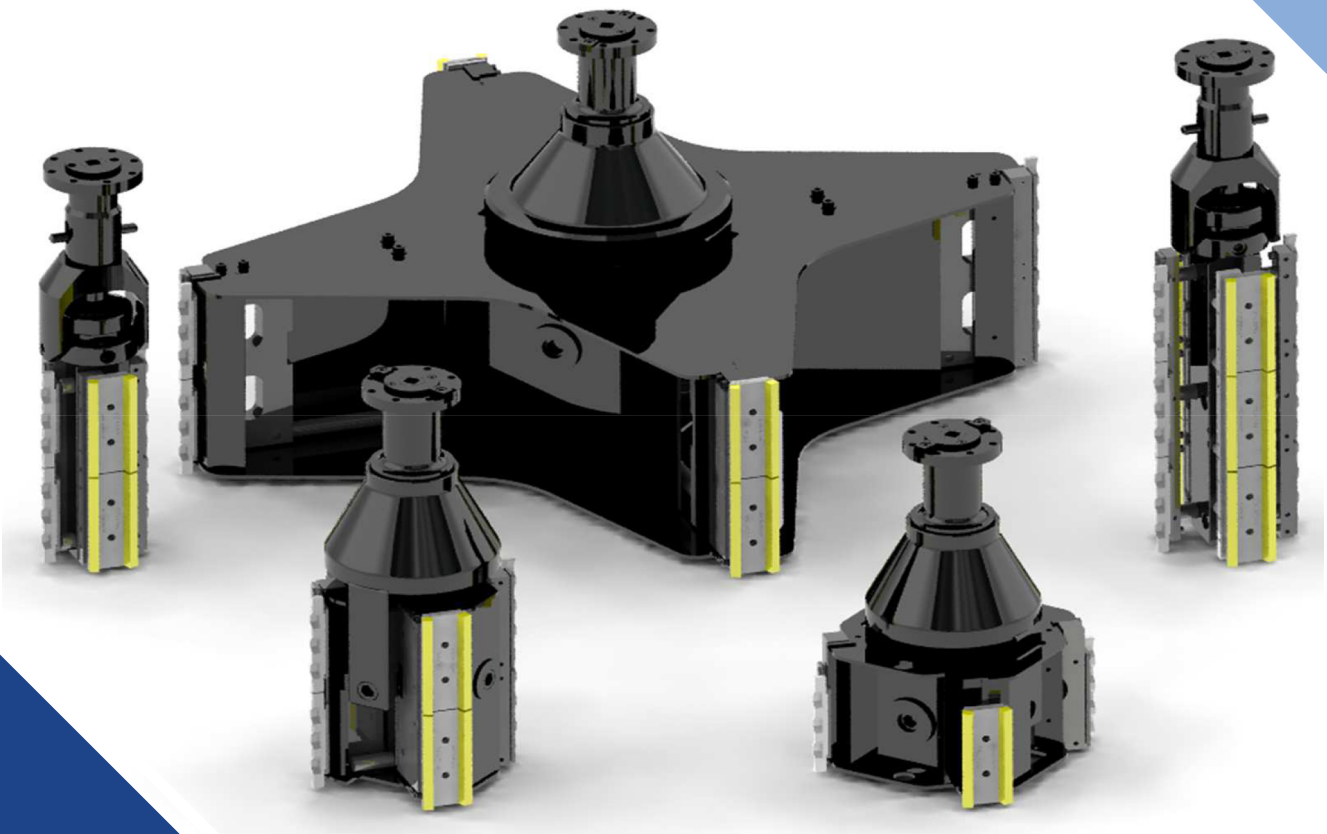

Hone Heads

HD Super Tooling is a modular design. Customers can select combinations of honing head, stone carriers and stone supports to provide the optimum honing solution for any bore diameter from 108mm to 1222mm.

In addition to the diameter, customers can also have the option to choose either a short, standard or long series hone tool in combination with a selection of stone configurations as well as select from Delapena's range of standard or super abrasives.

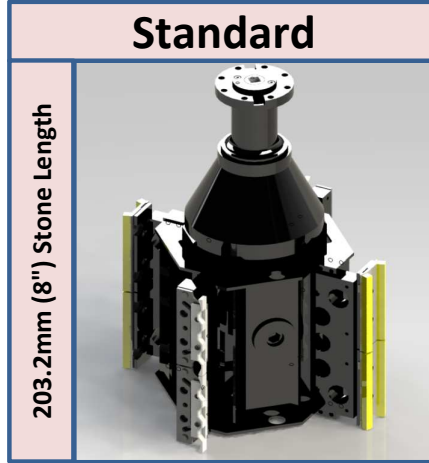
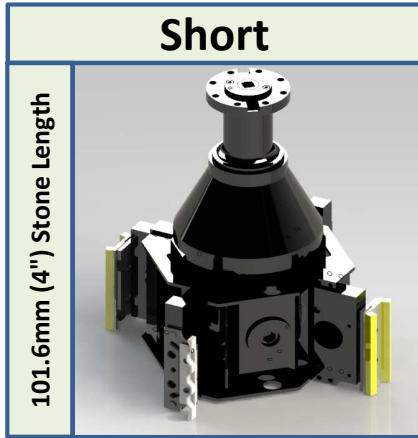

One complete head assembly consists of;
 A - 1 x Hone Head
 B - 1 x Carrier Set
 C - 1 x Support (above $\varnothing 205\text{mm}$)



Hone Head Selection Chart



Order the following part numbers to suit the honing diameter and stone length.

HONE DIA RANGE (mm)	A - HONE HEAD			B - CARRIER SET			C - SUPPORT		
	Short	Standard	Long	Short	Standard	Long	Short	Standard	Long
108 - 125	3201	3202	3207	3210	3211	3216	~	~	~
124 - 154				3212	3213	3217	~	~	~
150 - 205				3214	3215	3218	~	~	~
195 - 262	3203	3204	3208	3220	3221	3226	3251	3252	3257
257 - 342				3222	3223	3227	3253	3254	3258
340 - 452				3224	3225	3228	3255	3256	3259
450 - 562	3205	3206	3209	3230	3231	3244	3261	3262	3275
560 - 672				3232	3233	3245	3263	3264	3276
670 - 782				3234	3235	3246	3265	3266	3277
780 - 892				3236	3237	3247	3267	3268	3278
890 - 1002				3238	3239	3248	3269	3270	3279
1000 - 1112				3240	3241	3249	3271	3272	3280
1110 - 1222				3242	3243	3250	3273	3274	3281

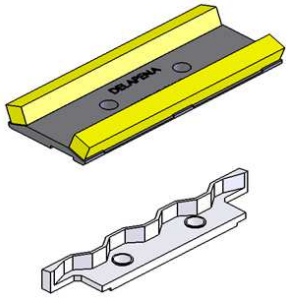
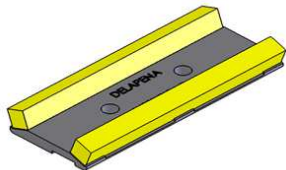
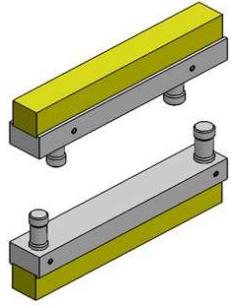
Stone Selection Chart

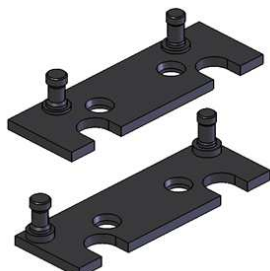
Order the following part numbers to suit the honing diameter;

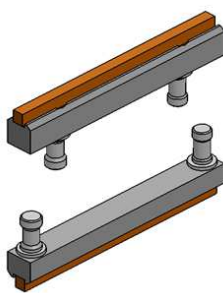
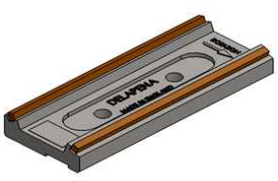
Standard Abrasives						
Stone Sets	2 double stones and 2 guides Stone = L100 x H8.5 x W8.5		4 double stones Stone = L100 x H8.5 x W8.5		4 oversize single stones Stone = L100 x H12.7 x W12.7	
						
	Part No.	HD2	Part No.	HD4	Part No.	LHD4 *
Adaptor Sets					Not required. Stone holders mount directly onto carriers.	
	Ø108 - 125	Part No.	3296	Ø108 - 125		
	Ø124 - 1222	Part No.	3295	Ø124 - 1222	Part No.	3297

Super Abrasives (diamond / CBN)						
Stone Sets	4 single stones Stone = L100 x H6.1 x W4.8		4 double stones Stone = L100 x H3.5 x W3.0			
						
	Part No.	SHD2	Part No.	SHD4		
Adaptor Sets	Not required. Stone holders mount directly onto carriers.					
	n/a		Ø108 - 125	Part No.	3298	
	n/a		Ø124 - 1222	Part No.	3297	

*** Important:**
when using LHD4 stone sets, actual honing diameter achievable will increase by 10mm (refer to hone head selection chart for size ranges).

Please specify grade when ordering stone sets. See Delapena standard tooling catalogue for available grades.

Delapena also supply special grades to suit customer specific requirements. Please contact Delapena.

Order the following quantities of Adaptors and Stone Sets to suit the hone head length;

Short	1 set per Head	Standard	2 sets per Head	Long	3 sets per Head
-------	----------------	----------	-----------------	------	-----------------

Replacement Parts

HONE HEAD

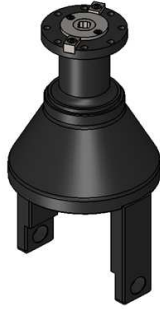
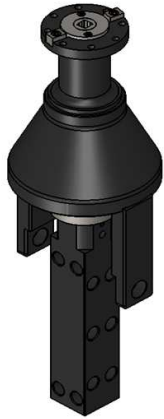

Uni-Joint
Assembly



Body
Assembly



Adj. Head
Assembly

	Short			Standard			Long		
Head Assembly	3201	3203	3205	3202	3204	3206	3207	3208	3209
Uni-Joint Assy	3202200	3203200	3205200	3202200	3204200	3206200	3202200	3208200	3209200
Body Assy	3201100			3202100			3207100		
Adj. Head Assy	3201300			3202300			3207300		

Carrier sets and support assemblies are supplied complete

Accessories

HD Mounting Tool

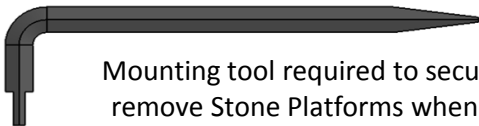

Mounting tool required to secure and remove Stone Platforms when using HD2, HD4 and SHD4 Stone sets.

Order 0423304

Heavy Duty Honing Oil

Specially developed for honing of heavy stock removal applications (25 or 205 litre)

Order 25LHD or 205LHD



Use on a Powerhone machine

Although HD tooling is designed primarily for use on horizontal honing machines, it can also be used vertically on Delapena Powerhone machines by using a driveshaft and adaptor set.

Order MT83022 Adaptor & MT83023 Driveshaft and specify driveshaft length required.



Delapena Honing Equipment Ltd

The Runnings · Cheltenham · Gloucestershire · GL51 9NJ · England

Tel: + 44 (0)1242 516341 · Fax: + 44 (0)1242 221246

sales@delapena.co.uk · www.delapena.co.uk

Delapena is an independently owned, British company.

